

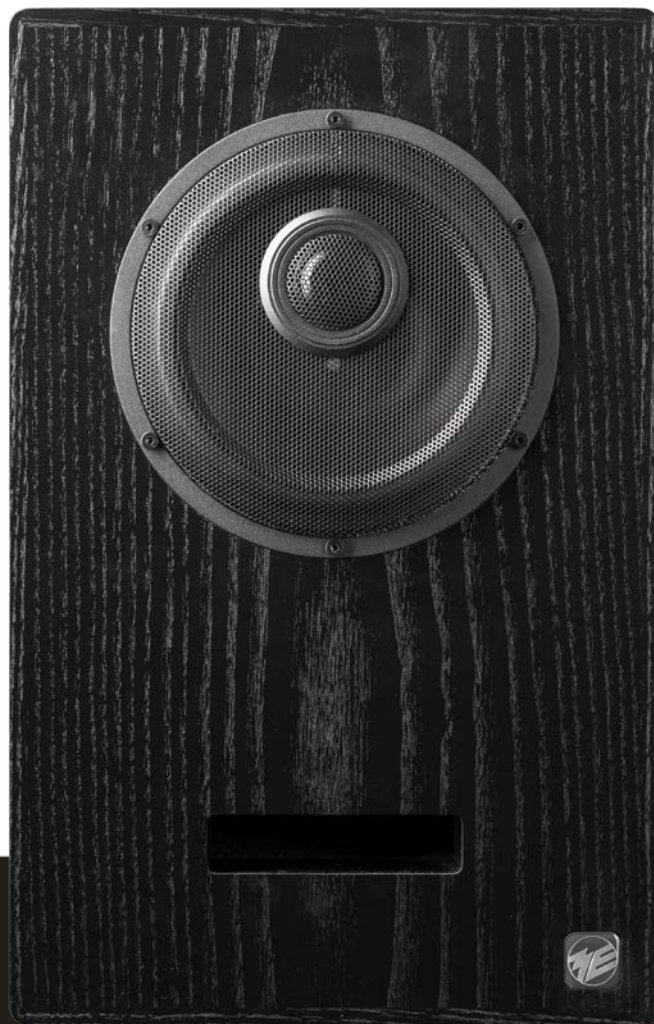

musikelectronic geithain

# MO-2



**Instructions for installation and use**

**Table of contents**

<b>1</b>	<b>Introduction</b>	<b>1</b>
<b>2</b>	<b>Disclaimer</b>	<b>2</b>
<b>3</b>	<b>System description</b>	<b>3</b>
<b>4</b>	<b>Basic information</b>	<b>4</b>
4.1	Guidelines	4
4.2	Safety instructions	4
4.3	Unboxing	6
4.4	Delivery contents	6
4.5	Cleaning	6
4.6	Environmental conditions	6
4.7	Guarantee acknowledgements	6
<b>5</b>	<b>Positioning</b>	<b>7</b>
5.1	Positioning near walls	7
5.2	Stereo operation	8
5.3	Surround operation	9
<b>6</b>	<b>Set-up the speakers</b>	<b>10</b>
6.1	Mains connection	10
6.2	Cable connection	10
6.3	Adjustment controller	11
6.4	Status indication	11
<b>7</b>	<b>Specifications</b>	<b>12</b>
<b>8</b>	<b>Acoustic measurements</b>	<b>13</b>
<b>9</b>	<b>Notes</b>	<b>14</b>

## **1 Introduction**

Dear customer,

Thank you for the trust you have put in us by buying these speakers. You decided upon a quality product that in regard to tonal and technical characteristics complies to the utmost expectations.

The usual burn-in period is not required, because the speakers are artificially aged in-house.

**Please read the technical description and manual to take advantage of the capabilities of these speakers and ensure safe operation.**

## **2 Disclaimer**

Technical data and appearances are subject to changes without notice. Errors and omissions excepted. Musikelectronic Geithain GmbH assumes no liability for any loss which may be suffered by any person who relies either wholly or in part upon any description, photograph or statement contained herein. Musikelectronic Geithain GmbH products are sold through authorized fulfillers and resellers only. Fulfillers and resellers are not agents of Musikelectronic Geithain GmbH and have absolutely no authority to bind Musikelectronic Geithain GmbH by any express or implied undertaking or representation. This manual is copyrighted. No part of this manual may be reproduced or transmitted in any form or by any means, electronic or mechanical, including photocopying and recording, or by any information storage or retrieval system without the prior written permission of Musikelectronic Geithain GmbH.

All rights reserved

Copyright © 2018 Musikelectronic Geithain GmbH

### **3 System description**

The loudspeaker of the type MO-2 is a compact studio monitor of our MO series. It is qualified for the use in near-field and middle-field applications as well as in outside broadcasting vans. With multichannel application we recommend the supplement by one of our active bass loudspeakers. Because of the construction in an active coaxial 2-way technology we can ensure sound colour compatibility to our studio control monitor loudspeakers. Moreover, by that constructive measure we can achieve high naturalness and homogeneity of the irradiated sound event. Also with regard to localization and the feasibly minimum imaging of phantom sound sources the MO-2 is seamless matched to all the loudspeakers of the RL and MO series. The directivity index was determined in such a manner that an operation is feasible up to 1m minimum base width.

The loudspeaker unit is supplied with a 160mm cone driver and a 25mm dome tweeter arranged coaxially. They are powered by separate MOSFET power amplifiers with an active crossover and electronic protection circuit in the back part of the cabinet. The MO-2 contains symmetric XLR input with calibrated input level adjustment. According to the position of the monitor box the amplitude/frequency curve can be well matched in the low- and in the high-frequency range as well as in the region about 300Hz by means of the controls on the back side.

A two-coloured LED indicates the state of the amplifier and warns of clipping. The loudspeaker is magnetically shielded for compensating stray fields.

The design of the box is finished in MDF with wood veneer. Various special stands and holds are available as optional extras. The corresponding appliances are integrated in the case.

## 4 Basic information

### 4.1 Guidelines

This product complies to requirements of current European and national guidelines (2004/108/EG Electromagnetical Compatibility). The conformity is ascertained, corresponding declarations and records are deposited with the manufacturer.

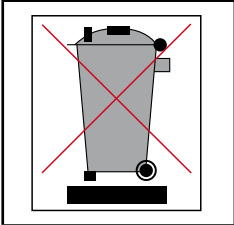

Products built by us belong to B2C-class of the WEEE guidelines and must not be disposed with domestic waste.

### 4.2 Safety instructions

Like using any other electrical device you should observe the following operation guidelines, safety instructions and warning signs to ensure optimum functionality and safety of operation!

- ❖ Read these instructions carefully.
- ❖ Keep these instructions during the life cycle at a safe place. The instructions are an important part of the product.
- ❖ Heed all warnings. Follow all instructions.
- ❖ The product may only be used in accordance with the information provided in the user manual. Before and during the usage of the amplifier please ensure that all recommendations, especially the safety recommendations in the user manual, are adhered to.
- ❖ Do not place this product on an unstable cart, stand, tripod, bracket, or table. The product may fall, causing serious injury, and damage to the product.
- ❖ The heat sink must not be blocked or covered. This product should not be installed unless proper ventilation is provided or manufacturer's instructions have been adhered to.
- ❖ Do not install the device near any heat sources.
- ❖ Do not expose the device to direct sun radiation.
- ❖ Do not install the device in rooms with high humidity.
- ❖ Do not try to insert anything into device openings.
- ❖ The device shall not be exposed to dripping or splashing and no objects filled with liquids shall be placed on the device.
- ❖ Clean only with dry or slightly moistened cloth.
- ❖ Protect the power cord from being walked on, pinched or damaged in any other way. Pay particular attention to plugs and the point where they exit the device.

- ◀ Do not attempt to service this product yourself as opening or removing cover may expose you to dangerous voltage or other hazards.
- ◀ Refer all servicing to qualified service personnel.

### 4.3 Unboxing

The speakers are shipped in proper condition. Unpack the speaker carefully and check for visible damages. In case of damages report them to your retailer. Keep the packaging, in case the speaker has to be transported in the future.

### 4.4 Delivery contents

- ◀ Speaker MO-2
- ◀ Mains cable
- ◀ Technical description and user manual

### 4.5 Cleaning

The speaker is made of real wood veneer and needs to be nurtured in the same way as furnishings. We advise quality wax polish to ensure durability of the veneer. Surfaces can also be cleaned with tidy, slightly dampened, fuzz-free, smooth cloth.

### 4.6 Environmental conditions

Ensure the following environmental conditions in your listening room:

- ◀ Operating temperature                    +15 °C ... +35 °C (+59 °F ... +95 °F)
- ◀ Storage temperature range            -25 °C ... +45 °C (-13 °F ... +113 °F)
- ◀ Relative humidity                        45 % ... 75 %

### 4.7 Guarantee acknowledgements

Opening the device by unauthorized personnel leads to all claims under guarantee expire. In case of destruction by overload, misuse or outside influences there are no claims under guarantee.



## 5 Positioning

Our speakers do not impose special requirements neither in stereo nor in multichannel set-ups. Nonetheless speaker positioning has influence on listening impression because every room is individually designed and furnished. The following advices are just guidelines that ease proper positioning. In addition we offer a measurement service to take advantage of the capabilities of your listening environment.

### 5.1 Positioning near walls

When speakers are installed near walls sound quality is physically affected. Every customary speaker behaves as a punctual sonic source in the low frequency range, with sonic waves spherical radiated without any constructional measures. Back wall reflections are unavoidable.

For optimum listening experience a minimum distance of 50 cm (19.7") to walls and furniture should be ensured. Avoid corner installations because unwanted bass accentuation could arise.

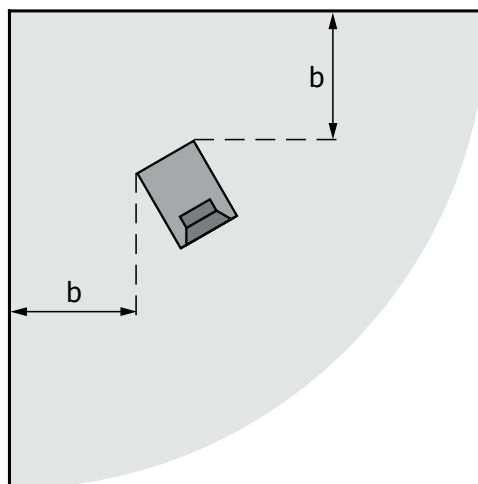

◀ Minimum distance to wall

$b \geq 50 \text{ cm (19.7")}$

## 5.2 Stereo operation

The optimum position of the speakers in your listening environment is the so-called stereo triangle (see figure). The base distance between the speakers and the distance to the hearing zone form an equilateral triangle (stereo triangle). A distance less than 1 m (3'3") or more than 2.6 m (8'6") should be avoided. For precise, spacial reproduction turn the speakers inside, directed to the hearing zone.

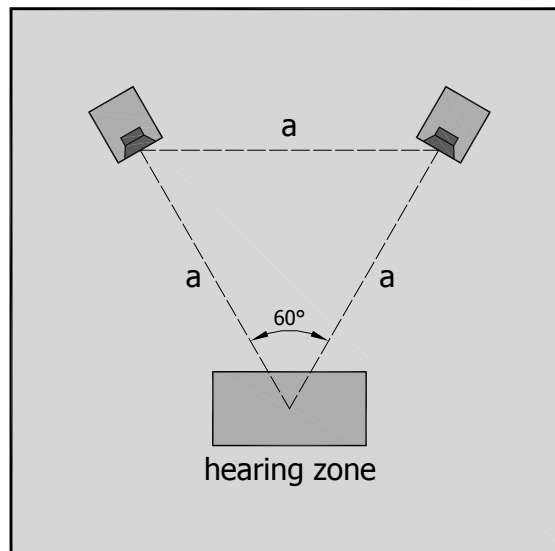

- ◀ Distance between speakers and your listening position  $a = 1\text{ m} \dots 2.6\text{ m}$  (3'3" ... 8'6")
- ◀ Adjust the speaker horizontally to the height of the ear at the listening position

### 5.3 Surround operation

In surround operation the stereo triangle (see Stereo operation) is extended to a circle. The hearing zone is the centre of this circle. Position all speakers in the same distance to the hearing zone. The centre speaker is positioned in the middle between both front speakers. Pay attention to positioning the front and rear speakers horizontally along one plane. The angle between centre and rear speakers should be about  $110^{\circ}$ – $120^{\circ}$ .

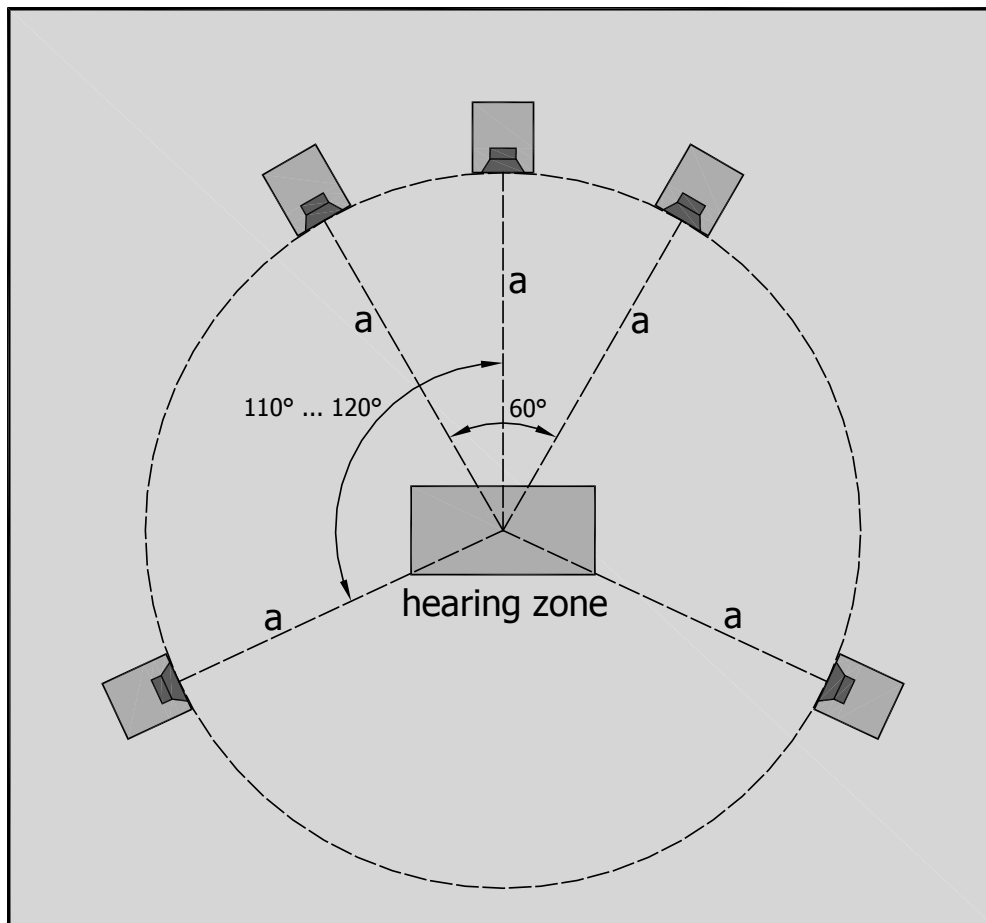

- ◀ Distance between speakers and your listening position  $a = 1\text{ m} \dots 2.6\text{ m}$  ( $3'3'' \dots 8'6''$ )

In case installation in the prescribed way is not possible in your listening room most decoding devices allow adjustments of single speakers.

## 6 Set-up the speakers

In this chapter we inform you how to connect your speakers to mains and your signal source. Ensure that the mains switch on the backside is in position "OFF". Only when your speaker is completely connected (see chapters 6.1 and 6.2) you can take the device into operation by use of the mains switch.

The speaker can be connected to every common pre-amplifier ( $U_a = 1V \dots 5V$ ;  $R_i < 600\Omega$ ).

### 6.1 Mains connection

Before start-up check the mains voltage stated on the backside of the device. If your local mains voltage does not match the specification of the speaker, please refer to your retailer or direct distribution. When the stated and your local mains voltage comply connect the mains connector of the speaker to the socket with the included mains cable.

### 6.2 Cable connection

The input of the integrated amplifier is electrically balanced. When your signal source also utilizes balanced connectors, please use a cable wired as stated in the table:

	Balanced connector (amplifier)	Balanced connector (signal source)	Unbalanced connector (signal source)
	<b>XLR</b>	<b>XLR</b>	<b>RCA</b>
Earth	Pin 1	Pin 1	Ring
Signal +	Pin 2	Pin 2	Tip
Signal -	Pin 3	Pin 3	Ring

When using a signal source with unbalanced outputs (RCA) you need to balance the connecting cables. This avoids hum and other noise interferences. The table and the following figure show the wiring.

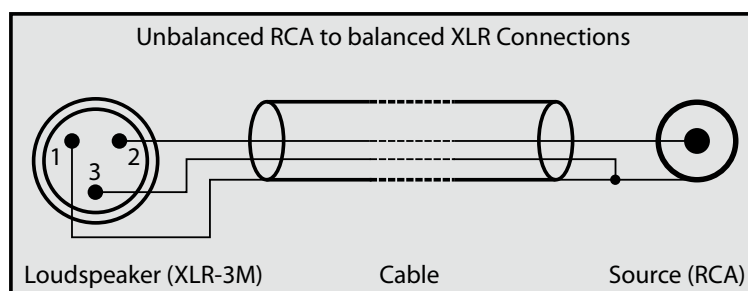

### 6.3 Adjustment controller

The "Level" controller is used for level adjustment over the full frequency range.

### 6.4 Status indication

The two-coloured LED at the front of the speaker is used as status indicator of the device.

- ◀ LED green: indicates normal operation of the device
- ◀ LED red: indicates the operation of the overload protection circuit;  
Output power limitation to protect the components from overloading

## 7 Specifications

General	Active 2-way monitor for use in small and middle audio-, video production studios, in mobile broadcast vans, and for multi-channel and near-field purposes 1 m (3'3") and 2.6 m (8'6")
Maximum SPL from 100 Hz ... 6 kHz	108 dB ... 112 dB / r = 1 m (3'3") (4π)
Bandwidth	46 Hz ... 20 kHz ±3 dB
Calibration:	
Acoustic output level / $P_E = -14$ dBu	83 dB / r = 1 m (3'3")
Directivity index from 200 Hz ... 10 kHz	increasing from 1 dB to 9,5 dB
Inherent noise sound level	≤ 7 dB(A) / r = 1 m (3'3")
Total harmonic distortion measured at 90 dB <sub>SPL</sub> / r = 1 m (3'3") from 100 Hz ... 10 kHz	≤ -45 dB
Nominal input level	+6 dBu (adjustable)
Input impedance	≥ 10 kΩ RC balanced
Electronic crossover frequency	2.6 kHz
Nominal output power of the amplifier	
LF	80 W / 4 Ω
HF	80 W / 4 Ω
Input connector	XLR 3F
Drive units	
Woofer	1 × 160 mm (6.5") cone
Tweeter	1 × 25 mm (1") dome
Operation and clipping indicator	LED on front
Power requirements	230 V ~ ±10%, 50 Hz ... 60 Hz 115 V ~ ±10%, 50 Hz ... 60 Hz (optional) 100 V ~ ±10%, 50 Hz ... 60 Hz (optional)
Power consumption	12 VA when idle max. 100 VA at full load
Mains connection	IEC power connector
Environmental conditions	
for use	+15 °C ... +35 °C (+59 °F ... +95 °F)
for storage	-25 °C ... +45 °C (-13 °F ... +113 °F)
humidity	45 % ... 75 %
Dimensions (H × W × D)	398 mm × 254 mm × 245 mm (15.7" × 10" × 9.7")
Weight	11 kg (24.3 lbs)
Design of the cabinet	MDF wood in ash black veneered; different veneers and colours on request
Lateral mounting	with lateral mounting; without lateral mounting on request

## 8 Acoustic measurements

All acoustic measurements are carried out under anechoic conditions with 1 m (3'3") distance.

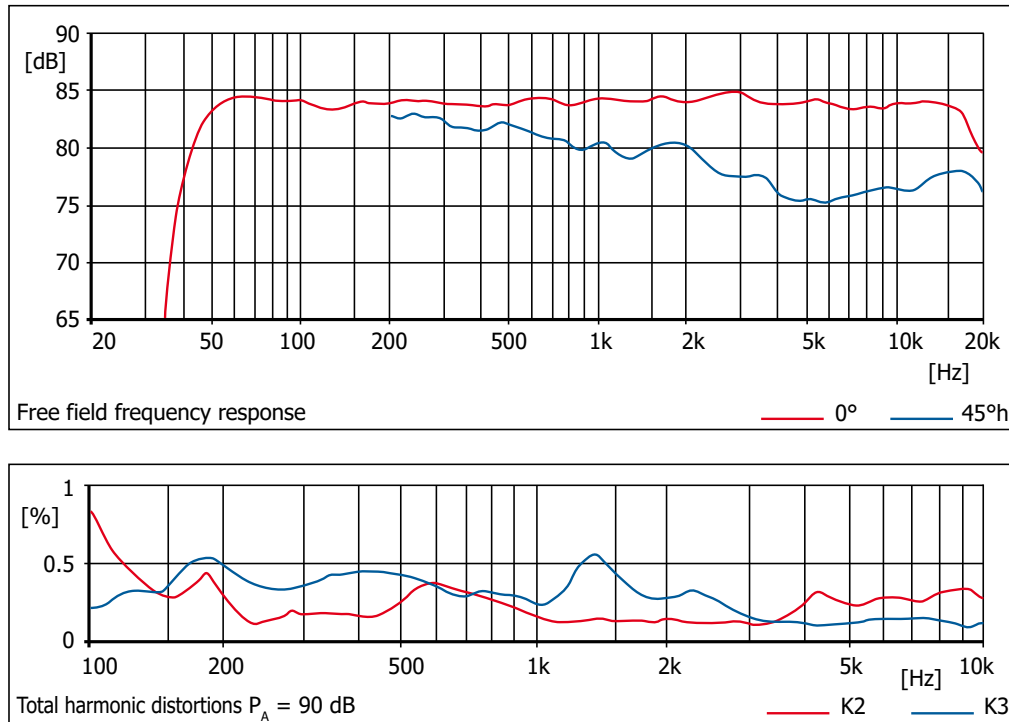

## 9 Notes









BDA\_MO-2\_18.05.2018\_ENV17



**musikelectronic geithain gmbh**

STUDIO MONITORING - HIGHEND LOUDSPEAKER - SOUND REINFORCEMENT  
SYSTEMS SYSTEMS

Nikolaistraße 7  
04643 Geithain / Germany

Phone: +49 (0) 34341 3110  
Fax: +49 (0) 34341 31144

Email: [info@me-geithain.de](mailto:info@me-geithain.de)

**[www.me-geithain.de](http://www.me-geithain.de)**